



2.5 Amps, 600 Volts N-CHANNEL POWER MOSFET

■ DESCRIPTION

The YR 3N60 is a high voltage and high current power MOSFET, designed to have better characteristics, such as fast switching time, low gate charge, low on-state resistance and have a high rugged avalanche characteristics. This power MOSFET is usually used at high speed switching applications in power supplies, PWM motor controls, high efficient DC to DC converters and bridge circuits.

■ FEATURES

- * $R_{DS(ON)} = 4.4\Omega @ V_{GS} = 10V$
- * Ultra low gate charge (typical 10 nC)
- * Low reverse transfer capacitance ($C_{RSS} =$ typical 5.5 pF)
- * Fast switching capability
- * Avalanche energy specified
- * Improved dv/dt capability, high ruggedness

■ SYMBOL

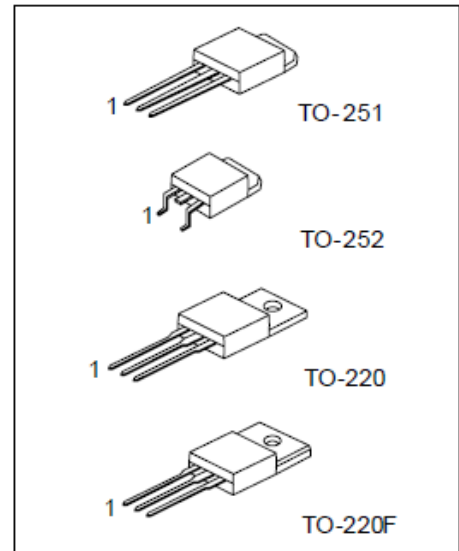
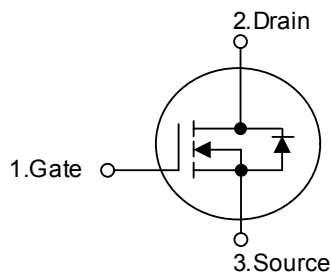

*Pb-free plating product number: 3N60

■ ABSOLUTE MAXIMUM RATINGS ($T_C = 25$, unless otherwise specified)

PARAMETER		SYMBOL	RATINGS	UNIT
Drain-Source Voltage	3N60	V_{DSS}	600	V
	3N65		650	V
Gate-Source Voltage		V_{GSS}	± 20	V
Avalanche Current - (Note 1)		I_{AR}	2.5	A
Continuous Drain Current	$T_C = 25^\circ C$	I_D	2.5	A
	$T_C = 100^\circ C$		1.6	A
Pulsed Drain Current, T_P Limited by T_{JMAX} - (Note 1)		I_{DM}	10	A
Avalanche Energy, Single Pulsed (Note 2)		E_{AS}	200	mJ
Avalanche Energy, Repetitive, Limited by T_{JMAX}		E_{AR}	7.5	mJ
Peak Diode Recovery dv/dt (Note 3)		dv/dt	4.5	V/ns
Power Dissipation		P_D	75	W
Junction Temperature		T_J	+150	
Storage Temperature		T_{STG}	-55 ~ +150	

Note: Absolute maximum ratings are those values beyond which the device could be permanently damaged. Absolute maximum ratings are stress ratings only and functional device operation is not implied.

■ THERMAL DATA

PARAMETER	SYMBOL	TYP	MAX	UNIT
Junction-to-Case	θ_{JC}		1.67	$^\circ C/W$
Junction-to-Ambient	θ_{JA}		62.5	$^\circ C/W$

■ ELECTRICAL CHARACTERISTICS ($T_C = 25$, unless otherwise specified)

PARAMETER		SYMBOL	TEST CONDITIONS	MIN	TYP	MAX	UNIT
Off Characteristics							
Drain-Source Breakdown Voltage	3N60	BV_{DSS}	$V_{GS} = 0 V, I_D = 250 \mu A$	600			V
	3N65			650			V
Drain-Source Leakage Current		I_{DSS}	$V_{DS} = 600 V, V_{GS} = 0 V$			10	μA
			$V_{DS} = 480 V, T_C = 125^\circ C$			100	μA
Gate-Source Leakage Current	Forward	I_{GSS}	$V_{GS} = 20 V, V_{DS} = 0 V$			100	nA
	Reverse		$V_{GS} = -20 V, V_{DS} = 0 V$			-100	nA
Breakdown Voltage Temperature Coefficient		BV_{DSS}/T_J	$I_D = 250 \mu A, \text{Referenced to } 25^\circ C$		0.6		V/
On Characteristics							
Gate Threshold Voltage		$V_{GS(TH)}$	$V_{DS} = V_{GS}, I_D = 250 \mu A$	2.0		4.0	V
Drain-Source On-State Resistance		$R_{DS(ON)}$	$V_{GS} = 10 V, I_D = 1.75 A$		3.7	4.4	Ω
Dynamic Characteristics							
Input Capacitance	C_{ISS}	$V_{DS} = 25 V, V_{GS} = 0 V, f = 1 MHz$			350	450	pF
Output Capacitance	C_{OSS}				50	65	pF
Reverse Transfer Capacitance	C_{RSS}				5.5	7.5	pF
Switching Characteristics							
Turn-On Delay Time	$t_{D(ON)}$	$V_{DD} = 300 V, I_D = 2.5 A, R_G = 25 \Omega$ (Note 4, 5)			10	30	ns
Turn-On Rise Time	t_R				30	70	ns
Turn-Off Delay Time	$t_{D(OFF)}$				20	50	ns
Turn-Off Fall Time	t_F				30	70	ns
Total Gate Charge	Q_G	$V_{DS} = 480 V, I_D = 2.5 A, V_{GS} = 10 V$ (Note 4, 5)			10	13	nC
Gate-Source Charge	Q_{GS}				2.7		nC
Gate-Drain Charge	Q_{DD}				4.9		nC

■ ELECTRICAL CHARACTERISTICS(Cont.)

PARAMETER	SYMBOL	TEST CONDITIONS	MIN	TYP	MAX	UNIT
Source- Drain Diode Ratings and Characteristics						
Drain-Source Diode Forward Voltage	V_{SD}	$V_{GS} = 0\text{ V}, I_S = 2.5\text{ A}$			1.4	V
Maximum Continuous Drain-Source Diode Forward Current	I_S				2.5	A
Maximum Pulsed Drain-Source Diode Forward Current	I_{SM}				10	A
Reverse Recovery Time	t_{RR}	$V_{GS} = 0\text{ V}, I_S = 2.5\text{ A},$		210		ns
Reverse Recovery Charge	Q_{RR}	$di_F/dt = 100\text{ A}/\mu\text{s}$ (Note 4)		1.2		μC

- Notes: 1. Repetitive Rating : Pulse width limited by T_J
 2. $L = 40\text{mH}, I_{AS} = 2.5\text{A}, V_{DD} = 50\text{V}, R_G = 25\ \Omega$, Starting $T_J = 25^\circ\text{C}$
 3. $I_{SD} \leq 2.5\text{A}, di/dt \leq 200\text{A}/\mu\text{s}, V_{DD} \leq BV_{DSS}$, Starting $T_J = 25^\circ\text{C}$
 4. Pulse Test: Pulse width $\leq 300\mu\text{s}$, Duty cycle $\leq 2\%$
 5. Essentially independent of operating temperature

■ TEST CIRCUITS AND WAVEFORMS

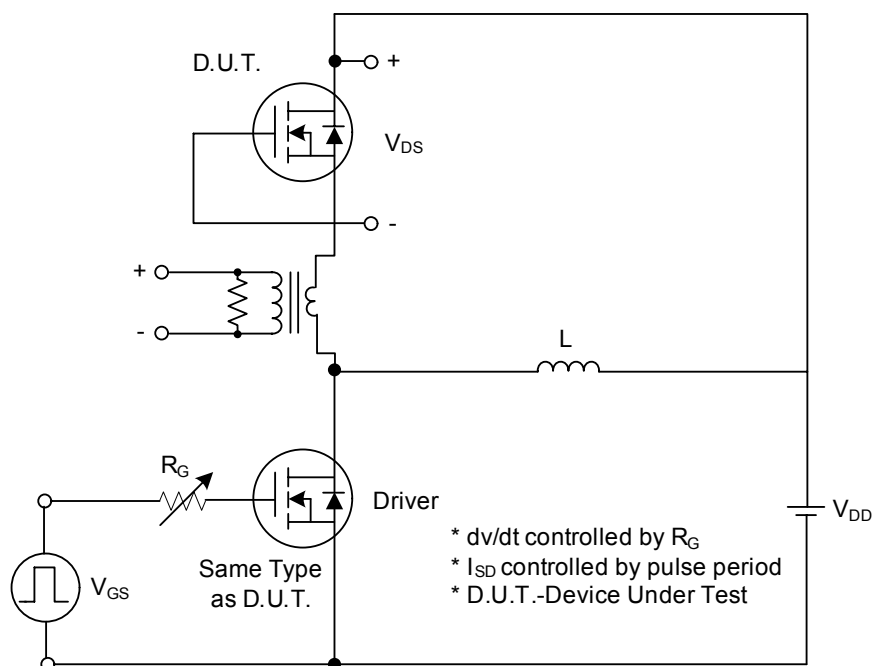

Fig. 1A Peak Diode Recovery dv/dt Test Circuit

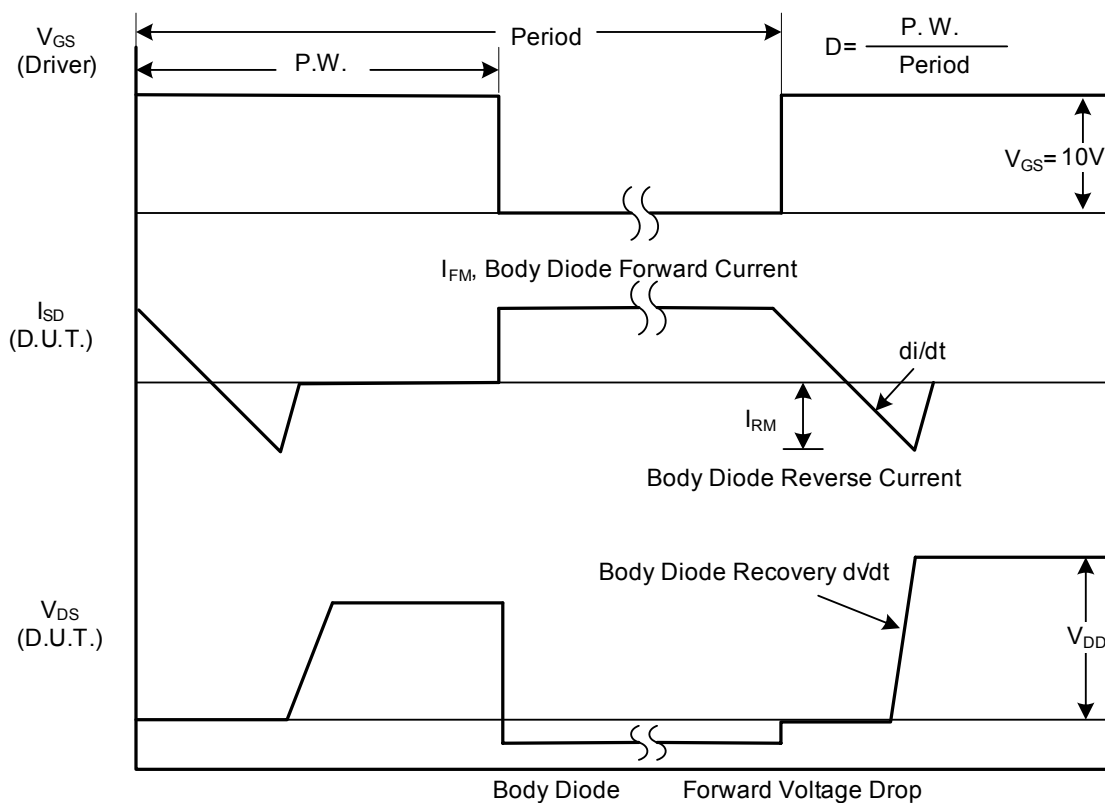

Fig. 1B Peak Diode Recovery dv/dt Waveforms

■ TEST CIRCUITS AND WAVEFORMS (Cont.)

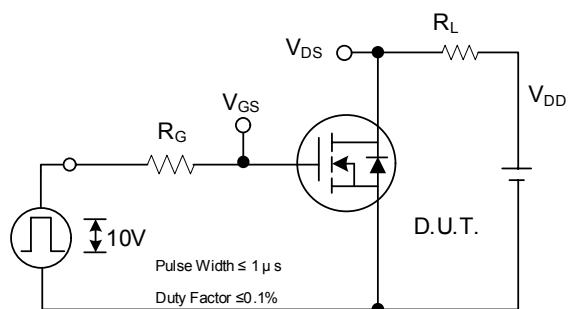

Fig. 2A Switching Test Circuit

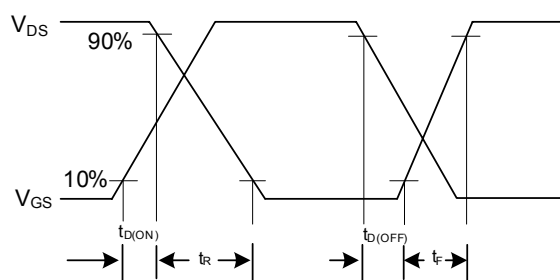

Fig. 2B Switching Waveforms

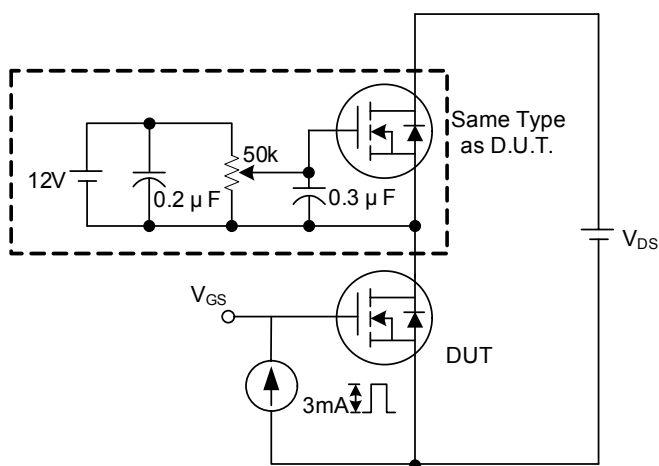

Fig. 3A Gate Charge Test Circuit

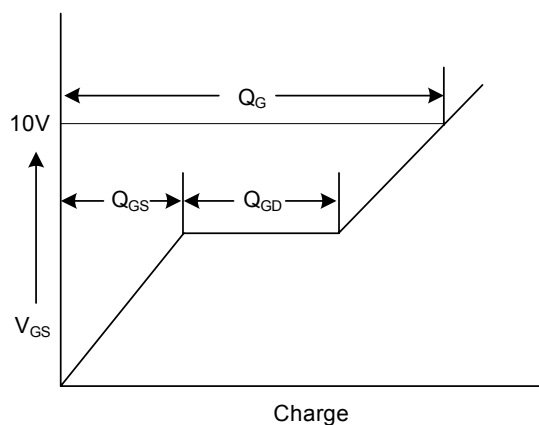

Fig. 3B Gate Charge Waveform

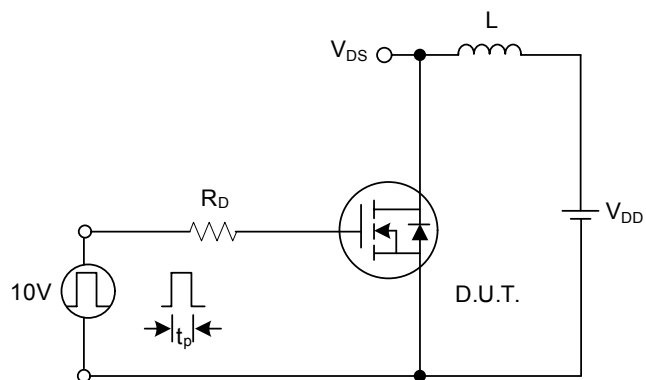

Fig. 4A Unclamped Inductive Switching Test Circuit

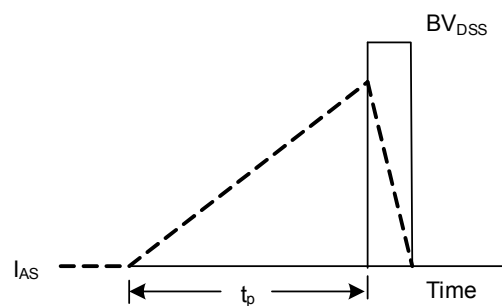
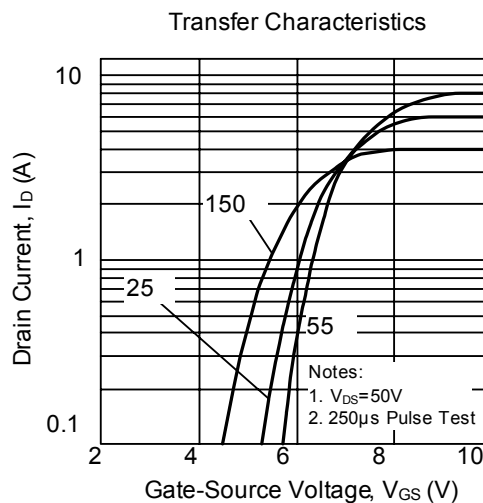
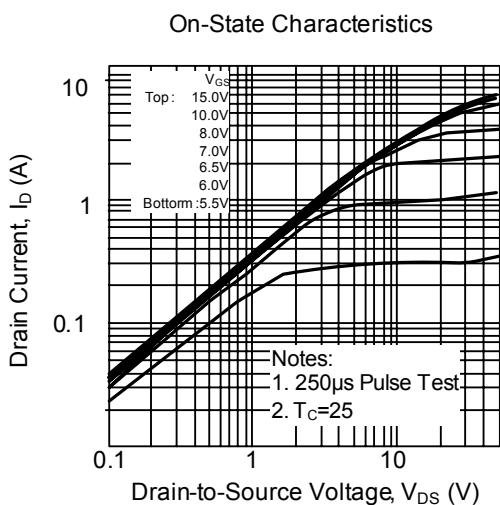
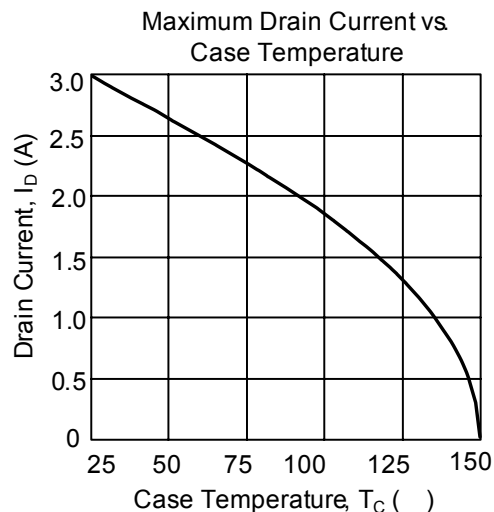
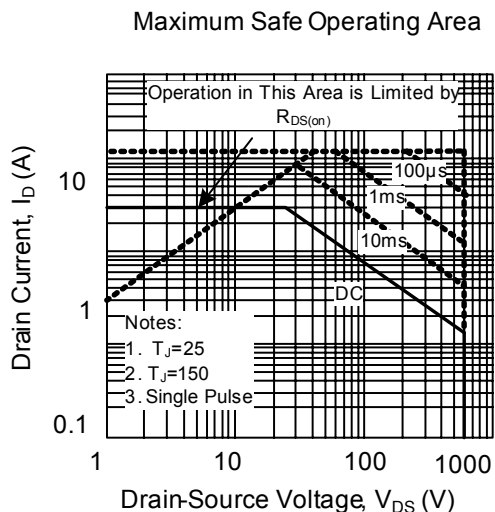
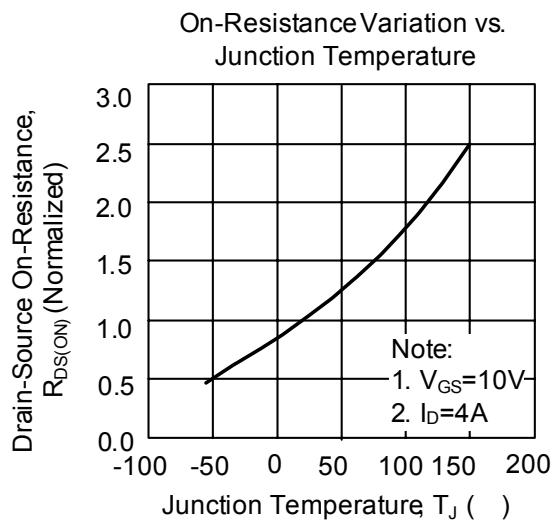
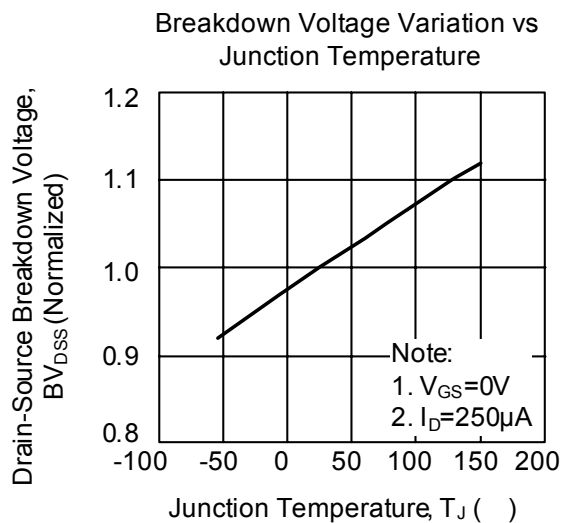

Fig. 4B Unclamped Inductive Switching Waveforms

TYPICAL CHARACTERISTICS



■ TYPICAL CHARACTERISTICS(Cont.)

On-Resistance Variation vs Drain Current and Gate Voltage

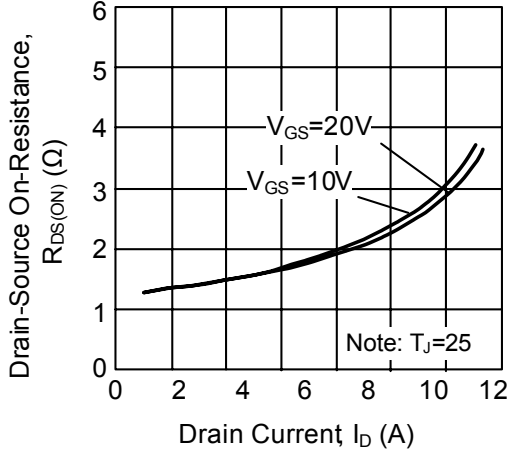

On State Current vs. Allowable Case Temperature

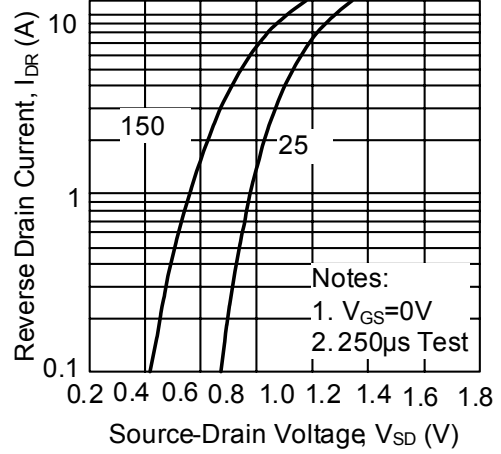

Capacitance Characteristics (Non-Repetitive)

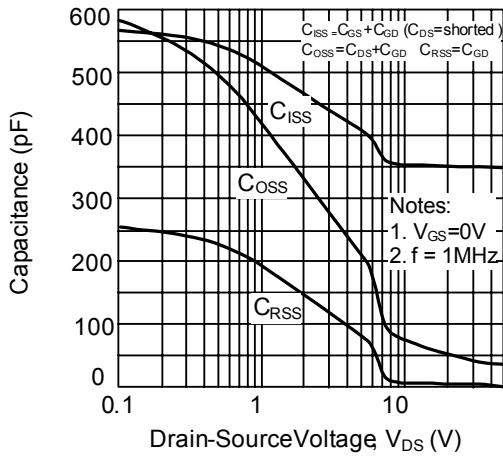

Gate Charge Characteristics

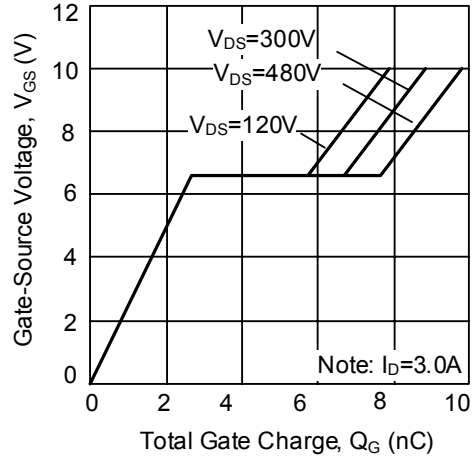

Transient Thermal Response Curve

